

CW-2940

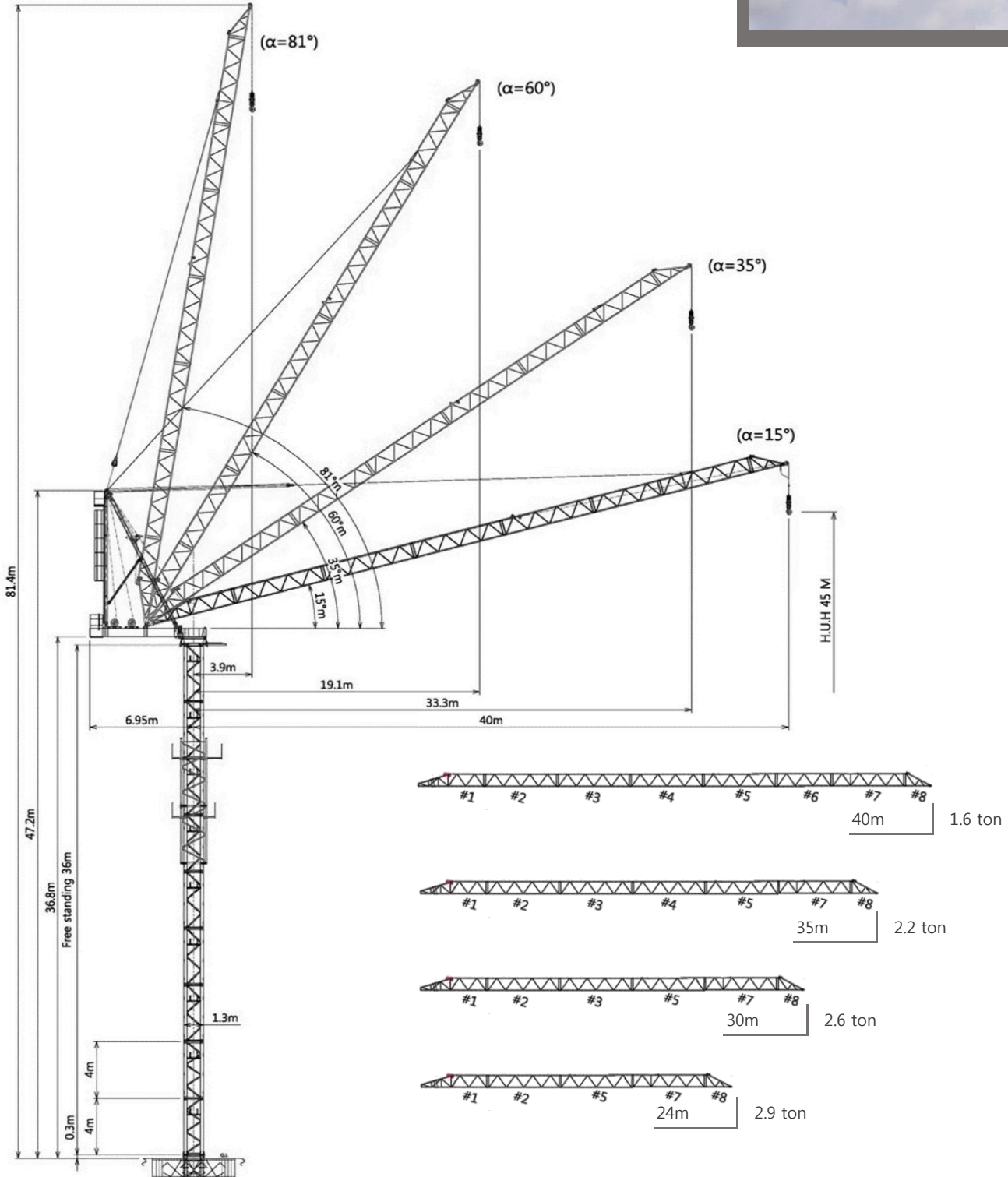

무인러핑크레인 / 2.9톤 / Max Jib 40m

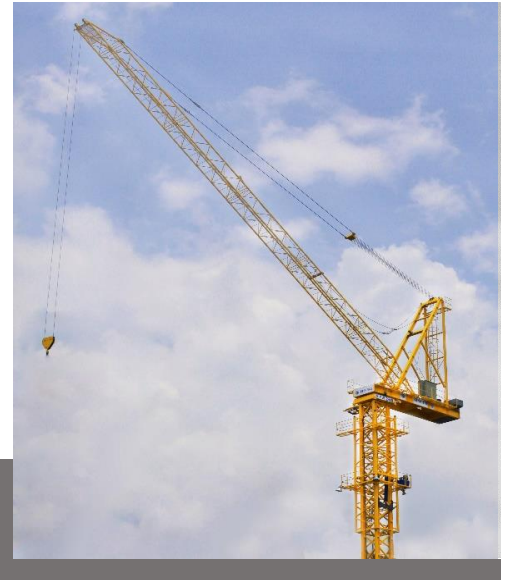



Load Capacity

Jib	Max Capacity	Radius & Capacity								
		m	21.0	24.0	27.0	30.0	32.0	35.0	37.0	40.0
40 m	2.9 ton	kg	2900	2900	2700	2500	2300	2100	1900	1600
35 m	2.9 ton	kg	2900	2900	2800	2700	2500	2200		
30 m	2.9 ton	kg	2900	2900	2900	2600				
24 m	2.9 ton	kg	2900	2900						

Specification

Free Standing		36 m		Max Install Height		130 m	
Hoist		2.9 ton	28 m/min	Inverter	15 kw	380 V / 60 Hz	Wire Drum : 350m / ø 12mm
		0.5 ton	50 m/min				
		0~0.2 ton	58 m/min				
Luffing		15~81°	3.3 m/min	Inverter	15 kw		Wire Drum : 200m / ø 12mm
Slewing			0.76 rpm	Inverter	3.75 kw		

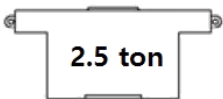
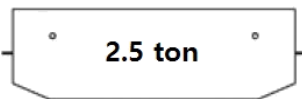
Ballast

A type	A' Type	B type
 2.5 ton	 2.5 ton	 1.8 ton

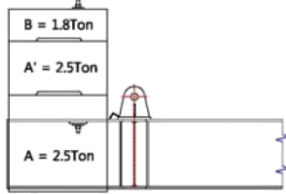
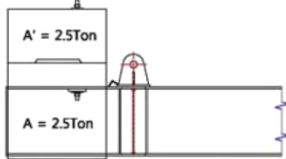
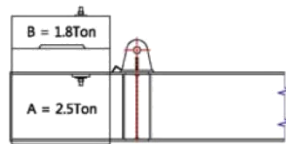
Jib	Weight	Installment
40 m 35 m	$A+A'+B = 6.8 \text{ ton}$	
30 m	$A+A' = 5.0 \text{ ton}$	
24 m	$A+B = 4.3 \text{ ton}$	

Foundation

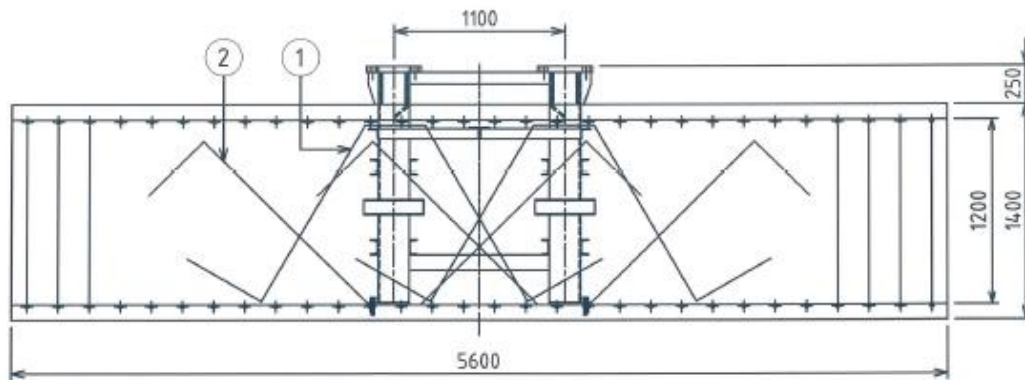
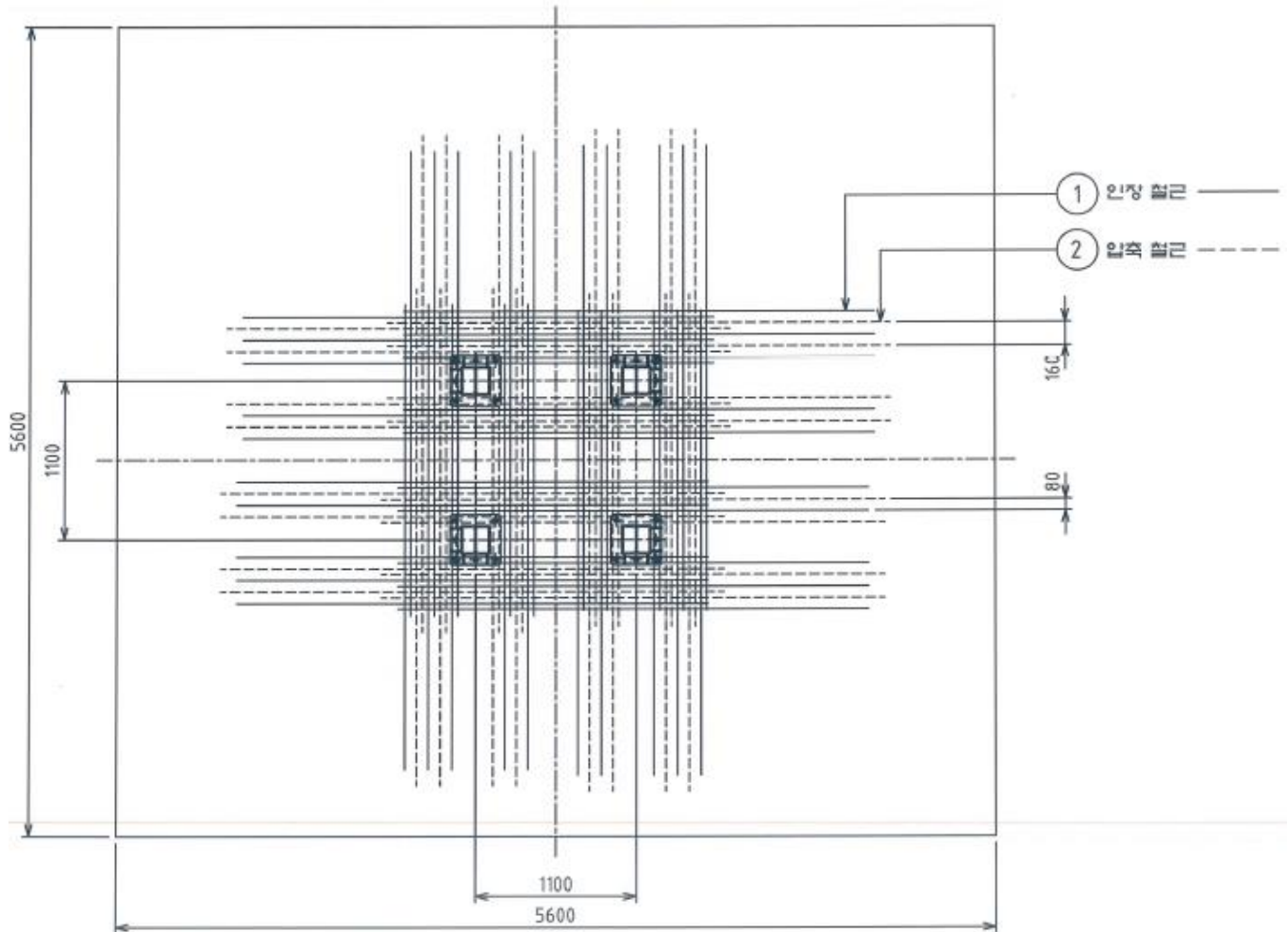

1 인장 철근
 10 x D25, L=3.198M per ANCHOR
 4(ANCHOR) x 10 = 40 pieces
 SD40

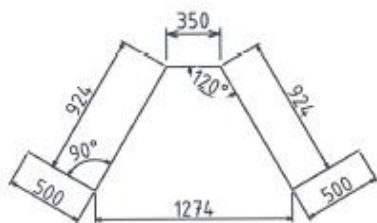

2 압축 철근
 8 x D25, L=3.512M per ANCHOR
 4(ANCHOR) x 8 = 32 pieces
 SD40

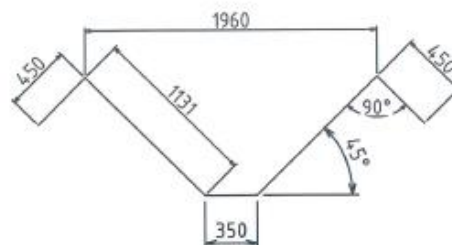

Foundation

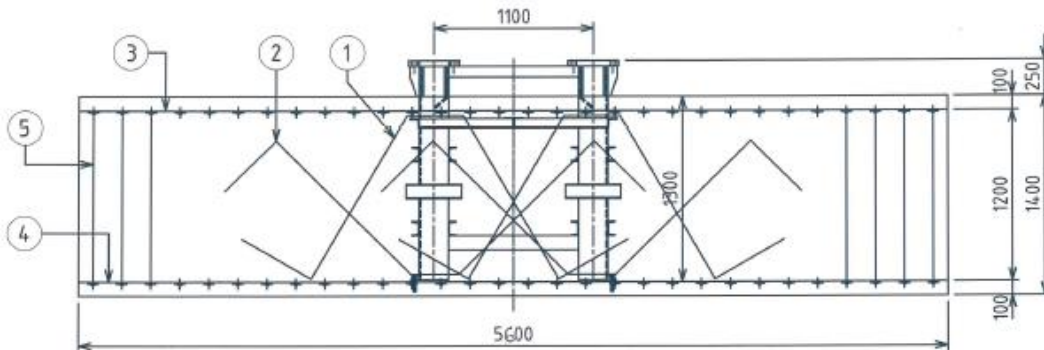
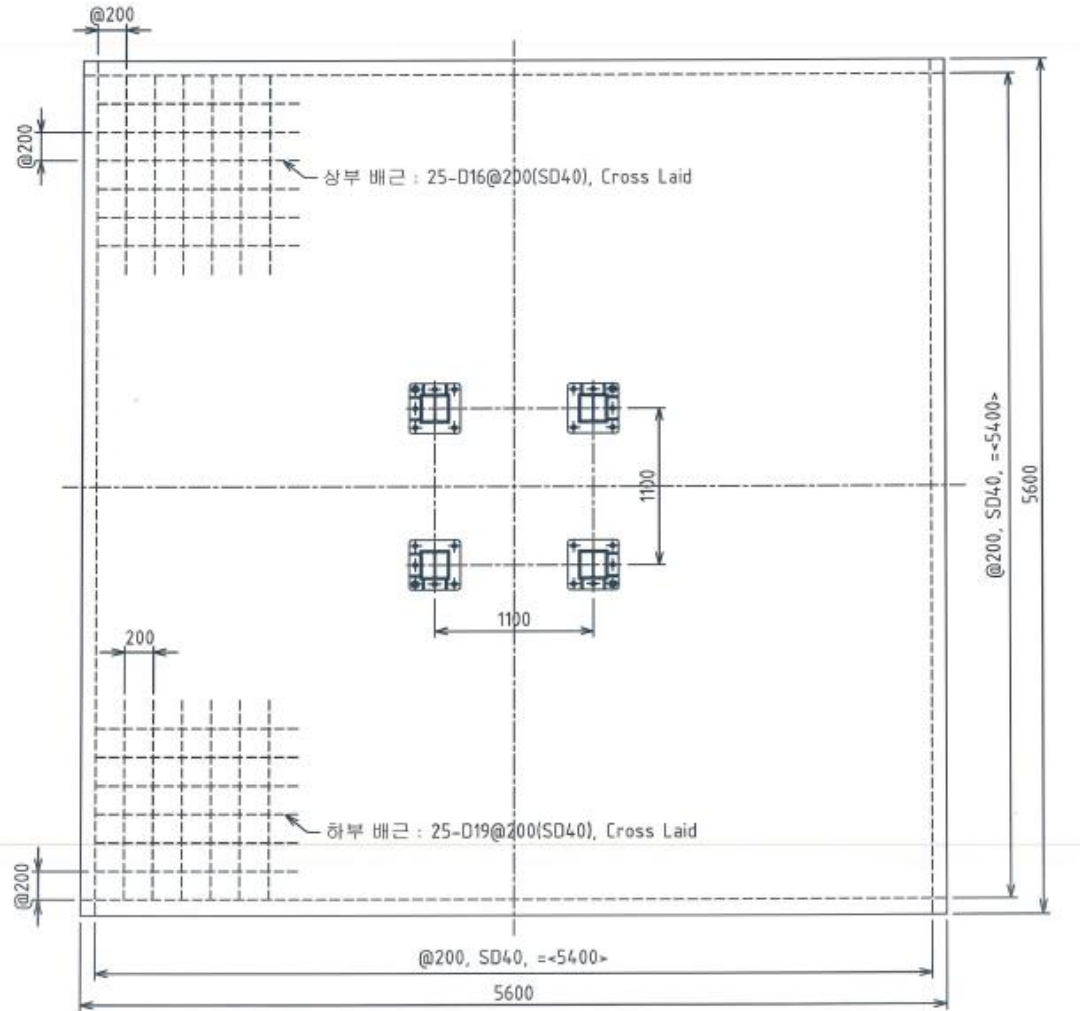

- ③ CROSS LAID D16(SD40)*@200*5400L - 60EA
- ④ CROSS LAID D19(SD40)*@200*5400L - 60EA
- ⑤ D16x1700L - 116EA

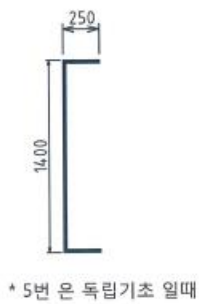

NOTE

1. CONCRETE 압축강도 : 240 kg/Cm²
2. 허용 지내력 : 20 ton/m²
3. 철근 : SD 40
4. 인장 및 압축 철근 간격 : 80mm

ANCHOR 설치시 주의사항

현장 여건상 기초형태 변경시 구고검토후 설치되어야함







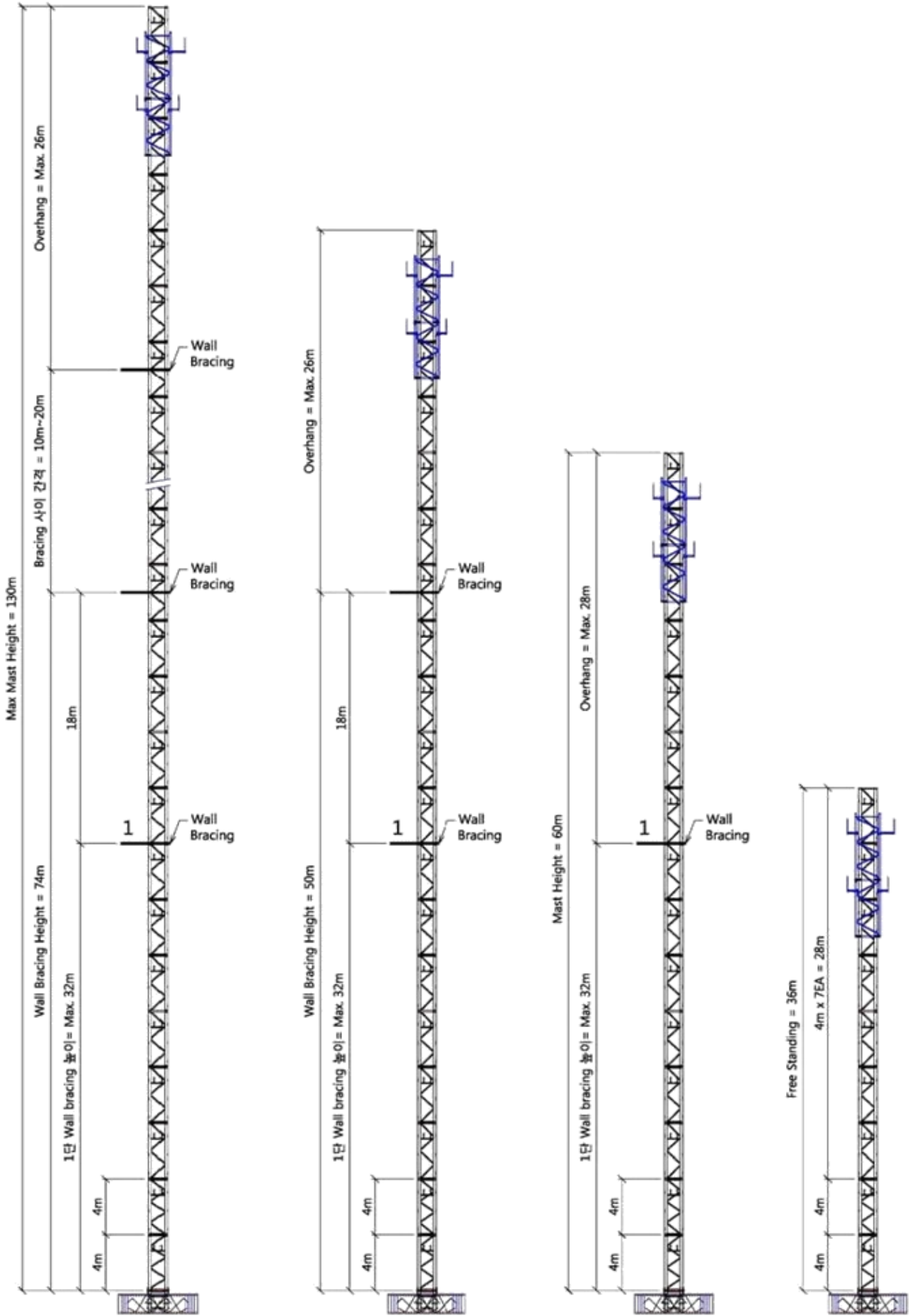



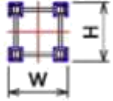



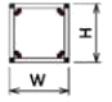

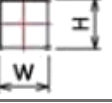

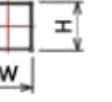
* 중요 사항

지내력이 부족한 지역에서는 TOWER CRANE의 기초가 침하되어 TOWER CRANE의 안전성에 위험이 따르므로 FRICTION PILE 및 기타방법으로 보강되어 져야 한다.

Mast Installment

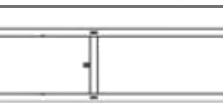

Packing List

No	Q'ty	Description	Length L	Width W	Height H	Weight (kg)			
1	3	Basic Mast Mast				4.0	1.45	1.45	1590
						4.0	1.30	1.30	1250
2	1	Telescopic Cage			8.9	1.8	1.8	3300	
3	1	Jib #1			6.35	1.125	1.125	510	
4	1	Jib #2				6.31	1.125	1.125	510
	1	Jib #3				6.31	1.125	1.125	405
	1	Jib #4			6.31	1.125	1.125	405	
	1	Jib #5				6.31	1.125	1.125	425
	1	Jib #6				4.81	1.125	1.125	320
	1	Jib #7				6.31	1.125	1.125	435
5	1	Jib #8			2.58	1.125	1.125	220	
6	1	Conter Jib Turn table Winch-2set Platform			7.86	1.83	1.55	4550	
7	1	Hook			0.75	0.25	0.98	104	
8	-	Weight A		1.86	0.85	0.84	2500		
		Weight A'		2.7	0.85	0.465	2500		
		Weight B		2.7	0.85	0.335	1800		
9	1	Tower Head Platform		10.8	1.73	1.2	2357		



청우 T&G

■ **본사 및 공장**

주소: 경남 양산시 산막공단북9길 112
 전화: 055-381-7823 팩스: 055-381-7825
 이메일: chungwoo2014@naver.com

■ **영업사무소**

주소: 경기도 남양주시 진접읍 해밀예당1로 216번길 20-13
 전화: 031-575-0886 팩스: 0303-3130-0886
 이메일: cw_sales@naver.com